

Induction Motors

KIS Series 200 W

Frame Size 110 mm



Parallel Shaft Gearhead

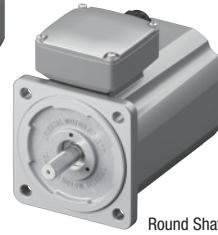

Round Shaft Type

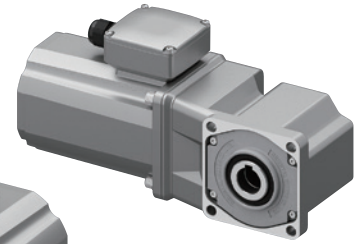

Right-Angle Hollow Shaft Gearhead

Specifications - Continuous Rating

Product Name	Output [W]	Voltage [VAC]	Frequency [Hz]	Current [A]	Starting Torque [mNm]	Rated Torque [mNm]	Rated Speed [r/min]
Terminal Box Type							
7IK200VES3T2-□S 7IK200VAS-ES3T2	200	Three-Phase 220	50	1.00	1690	1350	1420
			60	0.90	1410	1130	1700
		Three-Phase 230	50	1.02	1690	1350	1420
			60	0.89	1410	1130	1700
		Three-Phase 240	50	1.06	1690	1350	1420
			60	0.90	1410	1130	1700
7IK200VEU3T2-□S 7IK200VAS-EU3T2	200	Three-Phase 380	50	0.56	1400	1350	1420
			60	0.52	1300	1130	1700
		Three-Phase 400	50	0.56	1400	1350	1420
			60	0.51	1300	1130	1700
		Three-Phase 415	50	0.57	1400	1350	1420

*7IK200VAS-ES3T2 conforms to the Electrical Appliance and Material Safety Law.

●The values in the tables are characteristics for motor only.

●No built-in overheat protection device (thermal protector) When there is an overload or the output shaft is locked, use the electromagnetic switch and the inverter's electronic thermal function to prevent motor burnout.

●Use an inverter setting frequency of 120 Hz or less when driving in combination with inverter.

Product Line

● Parallel Shaft Gearhead **GV** Gear

Price includes motor and gearhead.

◇ Terminal Box Type

Product Name	Gear Ratio
7IK200VES3T2-□S	5, 10, 15, 20
	30, 50
	100
7IK200VEU3T2-□S	5, 10, 15, 20
	30, 50
	100

●The following items are included with each product. Motor, Gearhead, Installation Screws, Parallel Key, Operating Manual

● Round Shaft Type

◇ Terminal Box Type

Product Name
7IK200VAS-ES3T2
7IK200VAS-EU3T2

●The following items are included with each product. Motor, Operating Manual

Permissible Torque

- The speed is calculated by dividing the motor's synchronous speed (50 Hz: 1500 r/min, 60 Hz: 1800 r/min) by the gear ratio.

The actual speed is a maximum of 10% less, depending on the load.

50 Hz

Unit: Nm

Product Name	Speed [r/min]	300	150	100	75	50	30	15
	Gear Ratio	5	10	15	20	30	50	100
7IK200V ■ 3T2 -□ S		6.1	12.2	18.2	24.3	34.8	58.1	70

60 Hz

Unit: Nm

Product Name	Speed [r/min]	360	180	120	90	60	36	18
	Gear Ratio	5	10	15	20	30	50	100
7IK200V ■ 3T2 -□ S		5.1	10.2	15.3	20.3	29.2	48.6	70

- A number indicating the gear ratio is entered where the box □ is located within the product name.
- Either ES, or EU indicating the power supply voltage is entered where the box ■ is located within the product name.

Dimensions (Unit = mm)

Installation screws are included. Dimensions for installation screws

The cable outlet of the terminal box can be changed and fixed in four different directions.

A number indicating the gear ratio is entered where the box □ is located within the product name.

Parallel Shaft Gearhead **GV** Gear

◇ Terminal Box Type

Product Name	Motor Product Name	Gearhead Product Name	Gear Ratio	L1	L2	Mass [kg]
7IK200VES3T2 -□ S	7IK200VGV-ES3T2 7IK200VGV-EU3T2	7GV □ BS	5~20	58.7	60	7.3
7IK200VEU3T2 -□ S			100	84.7	86	8.4

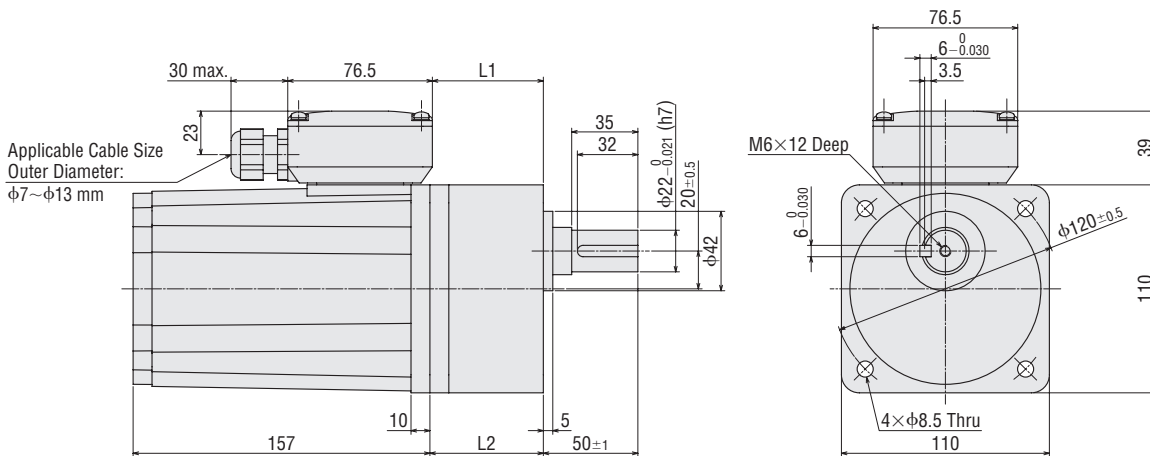

Round Shaft Type

◇ Terminal Box Type

7IK200VAS-ES3T2, 7IK200VAS-EU3T2

Mass: 5.4 kg

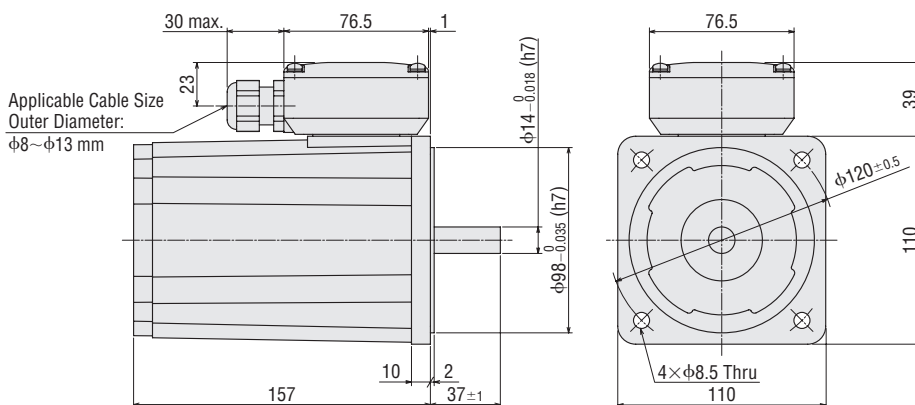

Specifications - Continuous Rating

Product Name Terminal Box Type	Output [W]	Voltage [VAC]	Frequency [Hz]	Current [A]
7IK200VES3T2-□RHS	200	Three-Phase 220	50	1.00
			60	0.90
		Three-Phase 230	50	1.02
			60	0.89
		Three-Phase 240	50	1.06
			60	0.90
7IK200VEU3T2-□RHS	200	Three-Phase 380	50	0.56
			60	0.52
		Three-Phase 400	50	0.56
			60	0.51
		Three-Phase 415	50	0.57

Gear Ratio		5	9	15	18	30	50	100	180	
Speed [r/min]	50 Hz	300	166	100	83	50	30	15	8.3	
	60 Hz	360	200	120	100	60	36	18	10	
Rated Torque [Nm]	50 Hz	4.9	8.9	14.8	17.7	29.6	40	56.5	60	
	60 Hz	4.2	7.4	12.4	14.8	27.7	40	54.5	60	
Permissible Inertia J [$\times 10^{-4} \text{kgm}^2$]		100	320	1000	1400	3900	9300	180000	37000	
	Instantaneous Stop	50	162	450	648	1800	5000			
Permissible Radial Load [N] *	10 mm from Installation Surface	1200					2200			
	20 mm from Installation Surface	1100					2000			
Permissible Axial Load [N]	300									

*The radial load at each distance can be calculated with a formula.

●The speed is calculated by dividing the motor's synchronous speed (50 Hz: 1500 r/min, 60 Hz: 1800 r/min) by the gear ratio.

The actual speed is a maximum of 10% less, depending on the load.

●No built-in overheat protection device (thermal protector). When there is an overload or the output shaft is locked, use the electromagnetic switch and the inverter's electronic thermal function to prevent motor burnout.

●Use an inverter setting frequency of 120 Hz or less when driving in combination with the inverter. Keep the motor operating ambient temperature between 0 and 40°C.

Note

●Do not perform instantaneous bi-directional operations.

◇ Load Position

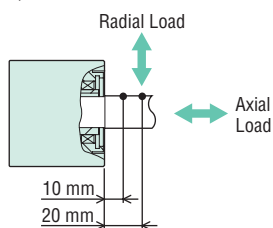

Distance from Installation Surface

Product Line

● Terminal Box Type

Product Name	Gear Ratio
7IK200VES3T2-□RHS	5, 9, 15, 18, 30
	50, 100, 180
7IK200VEU3T2-□RHS	5, 9, 15, 18, 30
	50, 100, 180

●A number indicating the gear ratio is entered where the box □ is located within the product name.

Included

Parallel Key (Stainless Steel)	Operating Manual
1 Piece	1 Copy

Motor and Gearhead Mounting Brackets

This is an aluminum die cast mounting bracket for gearheads and geared motors. There are also high-strength models available for high-power motors and gearheads. Long, horizontal holes make it easy to make fine adjustments during installation.



Product Line

Material: Aluminum alloy Surface treatment: paint

Standard AC Motors, Speed Control Motors

Select the pinion shaft type based on the gearhead to be attached.

Product Name	Applicable Product					
	Standard AC Motors		Brushless Motors		AC Speed Control Motors	
	Combination Type Geared Motor	Round Shaft Type	Combination Type	Round Shaft Type	Combination Type	Round Shaft Type
SOL0M3	–	–	–	BLH015-A	–	–
SOL0B	–	–	BLH015-□	–	–	–
SOL2M4F	2IK6, 2RK6	2IK6, 2RK6	BLM230	BLM230, BLM260	DSCI26	DSCI26
SOL2M4	–	–	BXS230, BLH230	BXS230, BLH230	–	–
SOL3M5F	–	3IK15, 3RK15	–	–	–	DSCI315
SOL3M6F	3IK15, 3RK15	–	–	–	DSCI315	–
SOL4M5F	–	4IK25, 4RK25	–	–	–	DSCI425
SOL4M5	–	–	–	–	–	–
SOL4M6F	4IK25, 4RK25	–	BLM460	–	DSCI425	–
SOL4M6	–	–	BXS460, BLH450	BXS460, BLH450	–	–
SOL5M6F	–	5IK40, 5RK40 5IK60, 5RK60 5IK90, 5RK90 5IK100	–	–	–	DSCI540, DSCI560, DSCI590
SOL5M6	–	–	–	–	–	–
SOL5M8F	5IK40, 5RK40 5IK60, 5RK60 5IK90, 5RK90 5IK100	–	BLM5120	BLM5120, BLM5200, BLM5300	DSCI540, DSCI560, DSCI590	–
SOL5M8	–	–	BXS5120, BLH5100	BXS5120, BLH5100	–	–
SOL6M8F	7IK200	–	BLM6200, BLM6300	–	–	–
SOL6M8	–	–	BXS6200, BXS6400	BXS6200, BXS6400	–	–

Letters are provided in the applicable products table for identifying the series.

Note

Not available for the following products.

KIS Series Right-Angle Geared Motor

Hollow Shaft Flat Gearhead (**GFS2G□FR, GFS4G□FR, GFS5G□FR, GFS6G□FR**)

A number indicating the gear ratio is entered where the box □ is located within the product name.

Flexible Couplings

These are clamp type couplings for connecting the motor/gearhead shaft with the driven shaft. Once the motor or gearhead is determined, the coupling can be selected.



Features

- Can be used with high torque
- Excellent for preventing eccentricity
- The structure features a separated hub and sleeve, so workability during installation is improved.

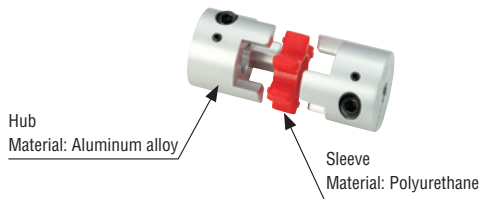

Product Number Code

MCL 40 12 15

- ① ② ③ ④

①	Flexible Coupling
②	Outer Diameter Dimension of Coupling 20 : $\phi 20$ mm - 65 : $\phi 65$ mm
③	Inner Diameter d1 (Smaller side) 05 : $\phi 5$ mm - 25 : $\phi 25$ mm
④	Inner Diameter d2 (Larger side) 05 : $\phi 5$ mm - 25 : $\phi 25$ mm

● Applicable products → Page C-246

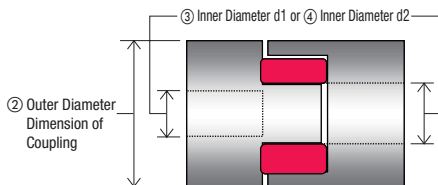

Product Line

Product Name
MCL20 <input type="checkbox"/>
MCL30 <input type="checkbox"/>
MCL40 <input type="checkbox"/>
MCL55 <input type="checkbox"/>
MCL65 <input type="checkbox"/>

● A number indicating the coupling inner diameter is entered where the box is located within the product name.

Selecting a Flexible Coupling

Once you have decided on a motor and gearhead as well as the driven shaft diameter, this determines the necessary coupling to use.

The coupling selection process is explained using the conditions below.

- Condition
 - Model: **2IK6** (shaft diameter $\phi 10$ mm)
 - Applicable Driven Shaft Diameter: $\phi 12$ mm
 - Uniform load*
- Selection Procedure
 1. Select a coupling appropriate for the **2IK6** with a uniform load from the applicable products table on the following page.
Coupling Type: **MCL30**
 2. From the applicable products table on the following page, find a product from the **MCL30** type that is compatible with a shaft diameter of $\phi 10$ mm and a driven shaft diameter of $\phi 12$ mm.

● Applicable Coupling Model

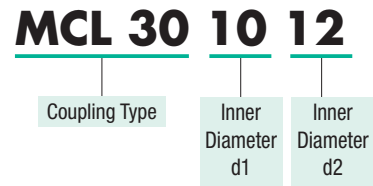

* Uniform load and impact load are the two types of load conditions.
 Uniform Load: When a uniform load is applied such as with a conveyor etc.
 Shock Load: When shock-inducing loads are applied from frequent starting and stopping

■ Applicable Products

● Standard AC Motors, Speed Control Motors

- Couplings can also be used with round shaft types. Select a coupling with the same inner diameter size as the motor shaft diameter.
- For the **BXII** Series round shaft type, refer to the **MCS** coupling.

■ Coupling Selection Table

● Standard AC Motors, Speed Control Motors

○: Uniform load ●: Compatible with uniform and shock load

Gearhead Model		Coupling Type	Shaft Diameter		Connected Device Shaft Diameter mm											
					05	06	08	10	12	14	15	16	18	20	22	25
Uniform Load	Shock Load		[mm]	φ5	φ6	φ8	φ10	φ12	φ14	φ15	φ16	φ18	φ20	φ22	φ25	
BLH015	BLH015	MCL20	06	φ6	●	●	●									
2IK, 2RK, BLM230, BXS230, BLH230, DSCI26	2IK, 2RK, BLM230, BXS230, BLH230, DSCI26	MCL30	10	φ10			●	●	●							
3IK15, 3RK15, DSCI315	—		12	φ12			○	○	○							
—	3IK15, 3RK15, DSCI315	MCL40	12	φ12			●	●	●	●	●					
4IK25, 4RK25, BLM460, BXS460, BLH450, DSCI425	—		15	φ15				○	○	○	○	○				
—	4IK25, 4RK25, BLM460, BXS460, BLH450, DSCI425	MCL55	15	φ15							●	●	●	●	●	
5IK40, 5RK40, 5IK60, 5RK60, 5IK90, 5RK90, 5IK100, BLM5120, BXS5120, BLH5100, DSCI540, DSCI560, DSCI590	5IK40, 5RK40, 5IK60, 5RK60, 5IK90, 5RK90, 5IK100, BLM5120, BXS5120, BLH5100, DSCI540, DSCI560, DSCI590		18	φ18								●	●	●	●	●
BLM6200, BLM6300, BXS6200, BXS6400, 7IK200	BLM6200, BLM6300, BXS6200, BXS6400, 7IK200	MCL65	22	φ22									●	●	●	

● The load in this table are of common use. Check the specifications values of each coupling for details.

● Letters are provided in the applicable products table for identifying the series.

Specifications

Coupling Type	Product Name	Dimensions				Normal Torque [Nm]	Mass [g]	Inertia J [$\times 10^{-4}$ kgm ²]	Permissible Eccentricity [mm]	Permissible Declination [°]	End Play [mm]									
		Outer Diameter [mm]	Overall Length [mm]	Shaft Hole Diameter d1 [mm]	Shaft Hole Diameter d2 [mm]															
MCL20	MCL200505	φ20	29	5	5	5.0	19	0.01	0.15	1.0	+0.8 0									
	MCL200506			5	6															
	MCL200508			5	8															
	MCL200606			6	6															
	MCL200608			6	8															
	MCL200808			8	8															
MCL30	MCL300808	φ30	43.5	8	8	12.5	66	0.083	0.2	1.0	+1.0 0									
	MCL300810			8	10															
	MCL300812			8	12															
	MCL301010			10	10															
	MCL301012			10	12															
	MCL301212			12	12															
MCL40	MCL401010	φ40	64	10	10	25.0	150	0.36	0.2	1.0	+1.2 0									
	MCL401012			10	12															
	MCL401014			10	14															
	MCL401015			10	15															
	MCL401016			10	16															
	MCL401212			12	12															
	MCL401214			12	14															
	MCL401215			12	15															
	MCL401216			12	16															
	MCL401414			14	14															
	MCL401415			14	15															
	MCL401416			14	16															
	MCL401515			15	15															
	MCL401516			15	16															
MCL401616	16	16																		
MCL55	MCL551515	φ55	76	15	15	60.0	350	1.6	0.2	1.0	+1.4 0									
	MCL551516			15	16															
	MCL551518			15	18															
	MCL551520			15	20															
	MCL551525			15	25															
	MCL551616			16	16															
	MCL551618			16	18															
	MCL551620			16	20															
	MCL551625			16	25															
	MCL551818			18	18															
	MCL551820			18	20															
	MCL551825			18	25															
	MCL65			MCL651515	φ65							87.5	15	15	160	570	3.7	0.2	1.0	+1.5 0
				MCL651516									15	16						
MCL651518		15	18																	
MCL651520		15	20																	
MCL651525		15	25																	
MCL651616		16	16																	
MCL651618		16	18																	
MCL651620		16	20																	
MCL651625		16	25																	
MCL651818		18	18																	
MCL651820		18	20																	
MCL651825		18	25																	
MCL652022		20	22																	
MCL652222		22	22																	
MCL652225		22	25																	

● The specifications above are the values when combined with Oriental Motor's motor and gearhead.

Watertight Extension Cables

These cables are used with watertight power relay boxes. Extensions of 5 m and 10 m are available.

Product Line

Number of Conductors	Product Name	Applicable Products	Length L [m]
4 Conductors	CC05AC43P	FPW Series	5
	CC10AC43P		10



Specifications

Cable Cores Construction: Refer to the dimension on the right

Finished Outer Diameter: $\phi 7.8$

Outer Sheath: Heat-resistant vinyl chloride

Dimensions (Unit mm)

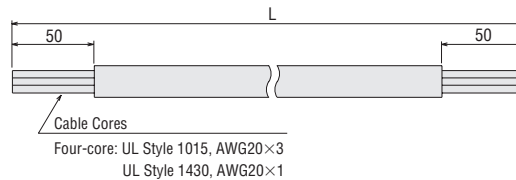

CR Circuit for Surge Suppression

This is used to protect the contacts of the relay or switch used in the bi-directional circuit or the instantaneous stop circuit of a motor.

Product Line

250 VAC (120 Ω , 0.1 μ F)

Product Name
EPCR1201-2



Dimensions (Unit mm)

Mass: 5 g

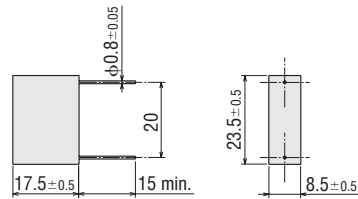

Orientalmotor

These products are manufactured at plants certified with the international standards **ISO 9001** (for quality assurance) and **ISO 14001** for systems of environmental management).

Specifications are subject to change without notice. This catalogue was published in January 2024.

ORIENTAL MOTOR (EUROPA) GmbH

European Headquarters

Schießstraße 44
40549 Düsseldorf, Germany
Tel: 0211 5206700 Fax: 0211 52067099

Spanish Office

C/Caléndula 93 - Ed. E - Miniparc III
28109 El Soto de La Moraleja,
Alcobendas (Madrid), Spain
Tel: +34 918 266 565

ORIENTAL MOTOR (UK) LTD.

UK Headquarters

Unit 5, Faraday Office Park,
Rankine Road, Basingstoke,
Hampshire RG24 8AH, U.K.
Tel: +44 1256 347090 Fax: +44 1256 347099

ORIENTAL MOTOR SWITZERLAND AG

Switzerland Headquarters

Badenerstrasse 13
5200 Brugg AG, Switzerland
Tel: +41 56 560 50 45 Fax: +41 56 560 50 47

ORIENTAL MOTOR ITALIA s.r.l.

Italy Headquarters

Via XXV Aprile 5
20016 Pero (MI), Italy
Tel: +39 2 93906346 Fax: +39 2 93906348

ORIENTAL MOTOR (FRANCE) SARL

France Headquarters

56, Rue des Hautes Pâtures
92000 Nanterre, France
Tel: +33 1 47 86 97 50 Fax: +33 1 47 82 45 16

Customer Service Center

(Support in German & English)

00800 22 55 66 22*

Mon - Thu: 08:00 - 16:30 CET

Friday: 08:00 - 15:00 CET

*Free Call Europe

info@orientalmotor.de

WWW.ORIENTALMOTOR.EU

EN | DE | UK | IT | FR | ES