

Elevator doors – more than just open and close



Founded in Switzerland. Available worldwide.

maxon – a strong global brand

maxon, with headquarters in Sachseln/Central Switzerland, has production sites in Switzerland, Germany, Hungary, South Korea, USA, France, Netherlands, Great Britain and China as well as sales companies in more than 30 countries. Our machines and product lines are developed in-house to guarantee cost-effective manufacturing of our products and enables us to create custom solutions to fit your specific application needs.

Precision Drive Systems

maxon develops and builds precision drive systems. Our brushless and brushed DC motors with ironless windings are among the best in the world. Flat motors with iron cores complete our modular product portfolio. maxon's modular system includes planetary and spur gearheads, spindle drives, as well as encoders and control electronics.



parvalux
by **maxon**

Parvalux, the fractional horsepower electric motor manufacturer and supplier, with state-of-the-art manufacturing and service facilities is a maxon company. Parvalux and maxon create the perfect combination of motor and gearbox and offer thousands of standard AC, DC brushed and DC brushless electric motor options.

Have you ever considered the mechanisms that are set in motion when we stand in front of an elevator door and press the button?

We frequently encounter automated doors in our everyday lives: on trams, public buses, and in buildings with elevators, to name just a few. What we often overlook in our daily use is the high level of technical sophistication needed for these automatic doors. They have to function flawlessly, be robust, and ensure passenger safety.

The requirements vary depending on the type and location of the automated door. In commercial buildings, such as train stations or shopping malls, the requirements for the functionality of automated doors such as those of elevators are very high because they are subjected to greater stress, longer operating hours, and higher visitor frequencies.

Behind every automated door lies a conventional mechatronic system. This means they consist of mechanical components such as belts, guide rollers, and door mechanisms, as well as electronic parts including motors, gears, and control systems with specialized door software. The door software is usually integrated into a higher-level system.

global.maxongroup.com/door-automation-solutions

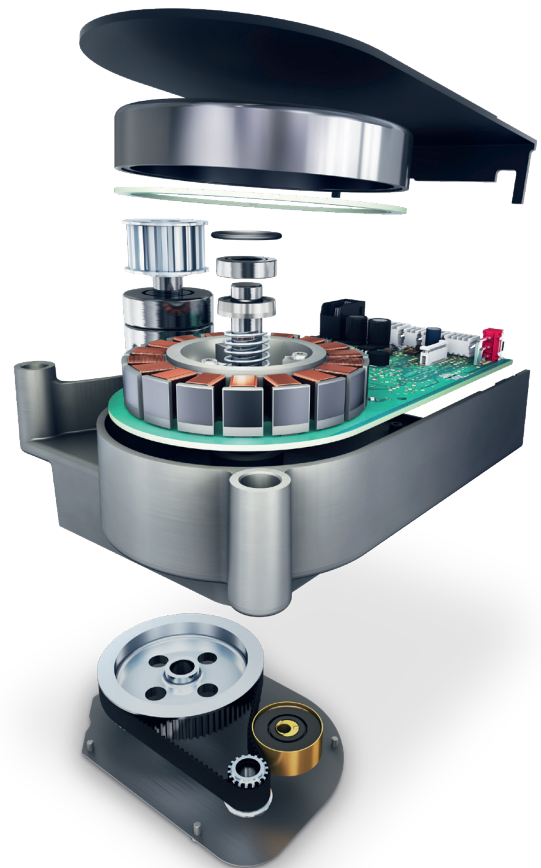

The driving force

The task on the surface is basic. 5 seconds to open the door, at least 2 seconds dwell time to allow passengers to enter/exit and 5 seconds to close the door. As covered previously however, the application and where the door is situated will provide some differing considerations. For context, the system in question is a Highrise elevator door system. Highrise means many stories, many stories mean many people and many people means a varied duty cycle. Take for instance you are running to the elevator and the motor is being told that everything is clear to close, until a fellow passenger holds the door for you. The motor must stop promptly, safely travel back and await another “clear” signal from the control system. You can imagine that, in an office building for example one person can use this elevator multiple times per day. Then, when you think of all other employees, visitors, etc. you have an idea of how hard a task this motor can have during its lifetime and how busy it will be.

When we talk about electric motors, it is important to understand the longevity of their active duty. Of course, value for money comes to mind, but safety especially where door automation is concerned must be our driving force.

The standard for mechatronic systems in door automation is that any system must surpass 1,000,000 cycles before it is deemed acceptable for use. Of course, most door/elevator manufacturers prefer a safety factor so would normally want to test to 1,200,000 cycles to approve a system. This would mean using the example duty cycle above, the motor would be tested continuously for over 100 days before it is approved. The system of our customer, however, requires 6,000,000 cycles. At the beginning of these cycles a new set off rollers and guides will be used with an assumed coefficient of friction. As time goes by and with each cycle, dirt, dust, and other foreign particles will alter the friction in the system and thus increase the work required from the motor. This is an important factor to consider.

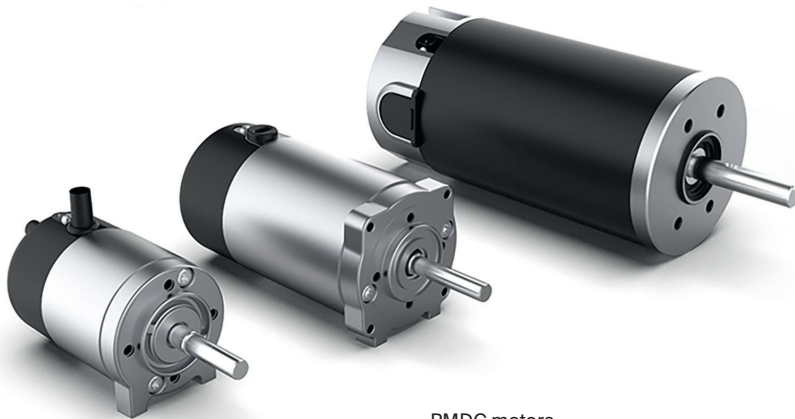

PMDC motors
(permanent magnet direct current)

Normally 1,200,000 test cycles to approve a system. The system of our customer, however, requires 6,000,000 cycles.





With this life cycle in mind, it was an easy decision to choose a brushless motor. With the control system already in place, the requirement of electronic commutation was not an issue and with brush life not being a concern it is the correct solution. On top of an otherwise standard and well performing motor were some finishing touches for the customer including custom marked connectors for ease of integration when systems are produced. On top of this, additional IP protection was required ensuring that high humidity, precipitation and build up of dust in application were not a concern.

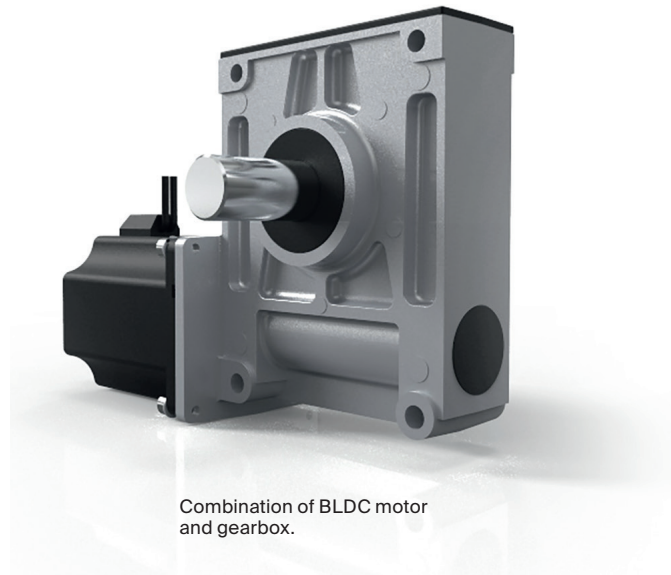

Combination of BLDC motor and gearbox.

Paired with this motor is Parvalux's trusted GB9 gearbox. A single stage, high efficiency, coupling driven right angled gearbox. The combination used a tried and tested 12.75:1 gearset with a bespoke Chemically Blacked output shaft to increase corrosive protection for the customer, whilst providing the mechanical interface required. The gearbox itself is an entirely sealed unit lubricated for the life cycle expected. The gearbox is also a coupling driven design meaning axial forces in both directions will not be acting on the motor bearings.

With the motor and gearbox being completely sealed from one another, it is possible to replace either component during maintenance and repair over the products life cycle providing a more sustainable approach.

Complete transparency



The customer opted for our EOL (end of line) testing capabilities.

This is a customer specific package which performs loaded testing on 100% of motors before they are packed and shipped from the flowline. Each unit is put through a test cycle measuring speeds, current and noise in both directions with and without load applied. Each of the units will have a specific work order and number on the nameplate with the test results automatically saved and filed. The customer can have access to all test data for each and every motor dispatched.

Safety is one of the key considerations when automatic doors are used.

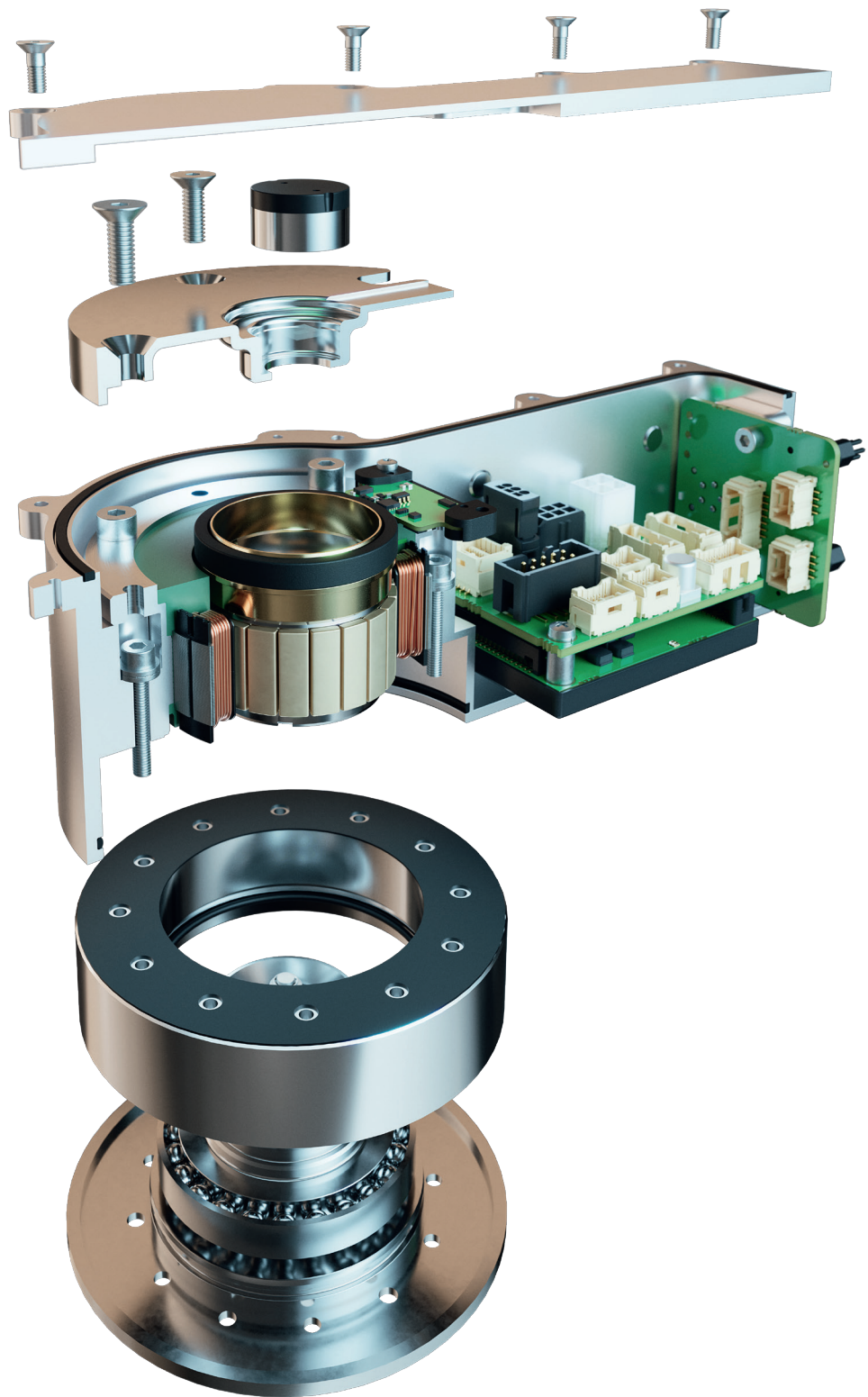

maxon not only develops and produces DC and BLDC motors, gearheads, sensors, and controllers, but is also able to combine the high-quality drive components in a mechatronic system.

Paired with complex controller

The door system itself has many relevant functions that determine its robustness, functionality, and behavior. What may seem like a simple sequence at first glance, namely opening and closing, is not so trivial when examined in detail. Since the same door application software has to work for doors of different dimensions, all relevant parameters need to be determined by means of an initial automated teach run. Mechanical width, mass, friction, and spring constants are derived from the motor current and fed into a model. Travel speeds and dynamic values are calculated using the model and entered in the door parameters. When the door closes, sensors monitor whether there are obstacles. If this detection fails for any reason, the motor current is limited by an envelope curve as the door closes: The door stops and performs a backward movement to ensure that nothing gets caught in the door. All relevant door information and motion states are efficiently communicated to the higherlevel control system.

The software function also enables collection and monitoring of door-related data that can change over time during operation. Temperature changes or elevated current values, for instance, serve as indicators of possible malfunctions. Detecting these in time can prevent malfunctions or, worse still, breakdowns. Safety is one of the key considerations when automatic doors are used. Therefore, monitoring of the door closing process is a crucial function.

Conclusion

Complex mechatronic drive systems only work if all components are of the highest quality and perfectly compatible. maxon not only develops and produces DC and BLDC motors, gearheads, and sensors, but also multi-axis Motion Controllers (MACS). This puts maxon in a position to combine high-quality drive components into a mechatronic system.

The benefits: a compact design, components configured specifically for the customer, and the guarantee of obtaining maximum performance from the drive system.

A crucial role in this system solution is fulfilled by maxon's programmable MACS controllers. For example, the **MiniMACS6-AMP-4** can dynamically and precisely control up to six brushed motors or up to four brushless motors. The controller is highly compact, programmable, and equipped with integrated power stages. Position feedback and master signals are received by means of incremental encoder inputs. Optionally, sin/cos encoders or SSI encoders can be connected. An array of digital inputs and outputs are used for processing sensor signals and for controlling actuators. The number of inputs and outputs can be expanded easily with a **CANopen I/O module**. Additionally, this controller is equipped with two **CAN interfaces** and one **USB interface**, enabling integration into a higher-level system. Optionally, other common industrial bus systems like **EtherCAT** can also be integrated.



The Motion Controller can handle a wide variety of tasks, ranging from autonomous repetitive processing of motion profiles and data logging to complex, jerk-optimized, or synchronized movements of multiple axes and controlling of complete kinematic modules.

Complex programming made easy with APOSS IDE

In complex application developments, such as those involving automated doors, questions quickly arise that concern the entire architecture.

Are there higher-level controllers?
Which interfaces are used for communication?
What are the requirements regarding real-time capability?
How many axes need to work together and in what way?
What are the requirements for dynamics and precision?

This is where the advantage of a single, fully compatible system really becomes apparent.

Using MACS controllers with the APOSS IDE integrated development environment offers great added value. ApossIDE is a comprehensive, license-free automation software tool that enables application-specific programming of all maxon's MACS controllers. This tool is also used for testing and debugging the motion control functions of all MACS devices. This allows drives to accurately execute the motion profiles demanded by the application.

A continuous harmony between electronic and mechanical components.

Door automation requires a continuous harmony between electronic and mechanical components to ensure a robust, safe and long-lasting product. Combining the powerful and flexible maxon control system with a reliable and bespoke Parvalux geared motor provided a great solution for the customer.

Contact our experts

For drive-related questions, our application developers are available to assist at all times with their wealth of expertise. Experienced system architects and application developers provide advice or develop custom solutions upon request. Fast results and significantly reduced development times provide a critical competitive edge. intralogistics@maxongroup.com

global.maxongroup.com/door-automation-solutions

A global network

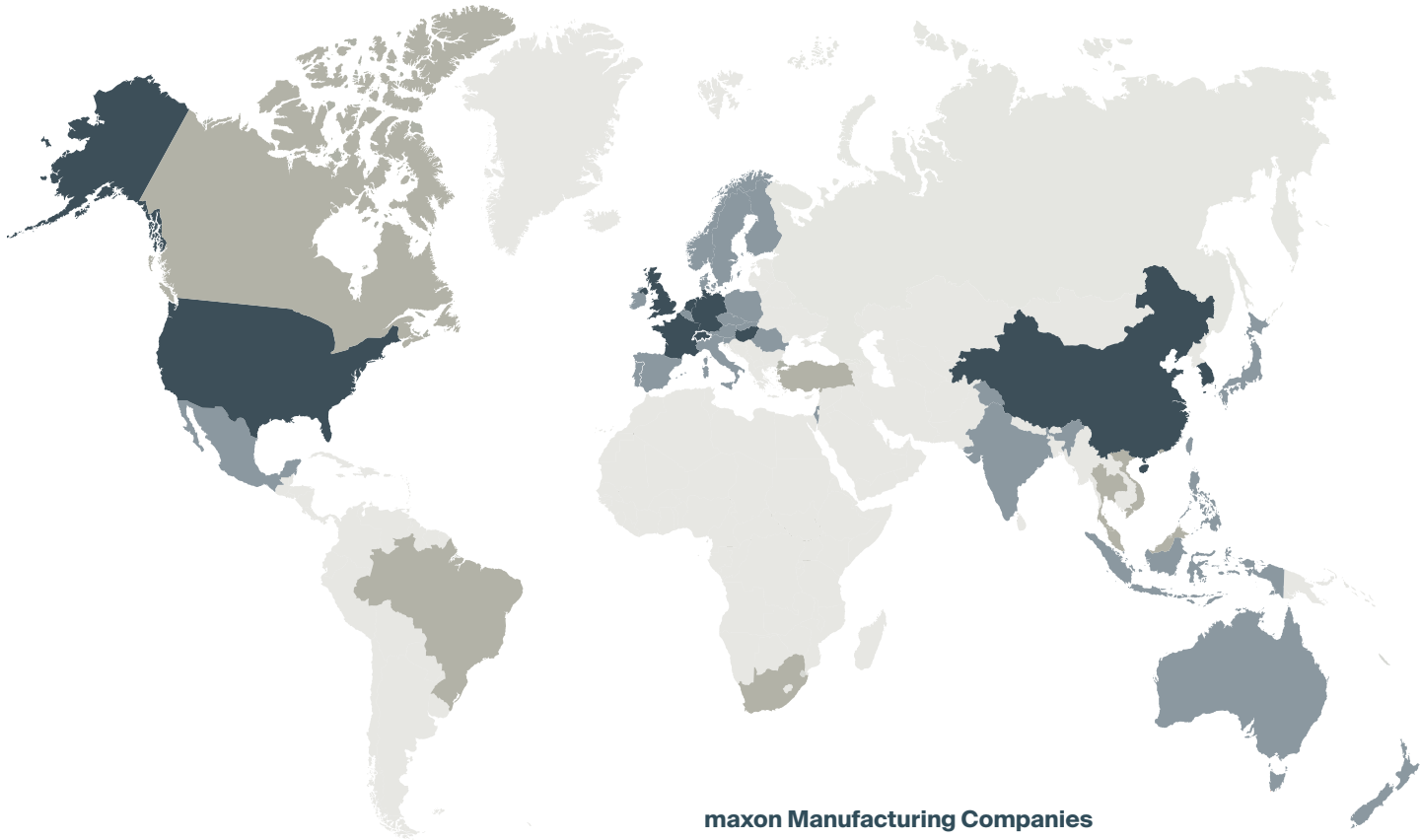

maxon Manufacturing Companies

Switzerland (Headquarters)	South Korea	USA
Germany	France	China
Hungary	Netherlands	Great Britain

maxon Sales Companies

Austria	Iceland	Portugal
Australia	India	Romania
Benelux	Indonesia	Serbia
Bulgaria	Ireland	Sweden
China	Israel	Switzerland
Croatia	Italy	Slovakia
Czech Republic	Japan	Singapore
Denmark	Latvia	Slovenia
Estonia	Lithuania	South Korea
Finland	Mexico	Spain
France	New Zealand	Taiwan
Germany	Norway	USA
Great Britain	Philippines	
Hungary	Poland	

maxon Sales Agents

Brazil	Malaysia	Turkey
Canada	South Africa	Vietnam
Hong Kong	Thailand	

For detailed contact information please visit
contact.maxongroup.com

