

Compact linear actuators for high-precision positioning

The DR Series is a combination of a motor and a ball screw and is characterised by compact size and high positioning accuracy. The different versions of the actuator (Fig. 1) not only ensure flexible application possibilities, but also help to save space in the machine. In the following, essential features and also the positioning accuracy are described in more detail.



Fig. 1: For flexible application possibilities, the DR Series is also available with linear table and with guide in addition to the standard version.

In the linear actuators, the hollow rotor, ball screw and nut are directly integrated without coupling. In order to minimise the overall length, large diameter ball bearings are also used, which rest against the outside of the ball screw nut (Fig. 2).

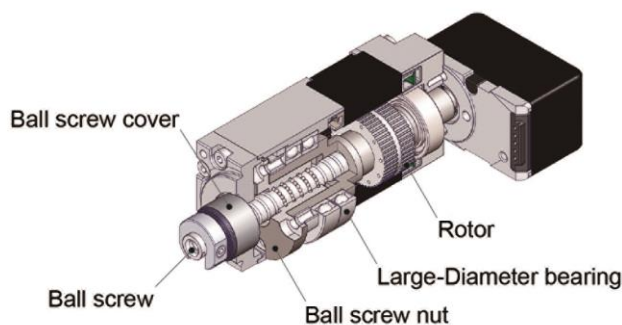

Fig. 2: Compact size through integration of hollow rotor and ball screw.

This design has the advantage that fewer external components have to be used, which reduces both the overall length and the assembly effort.

The guide version is equipped with long guide bushes with high rigidity, thus minimising spindle vibrations. For the higher rigidity, the bushings were positioned close to the mounting plate for the load. During the design phase, different bushing lengths were tested. For this purpose, an accelerometer was attached to the moving part and the frequencies were measured using an FFT analysis. As a result, the longer bushing led to lower vibrations. The vibration peaks were cyclical and were caused by the spindle (Fig. 3).

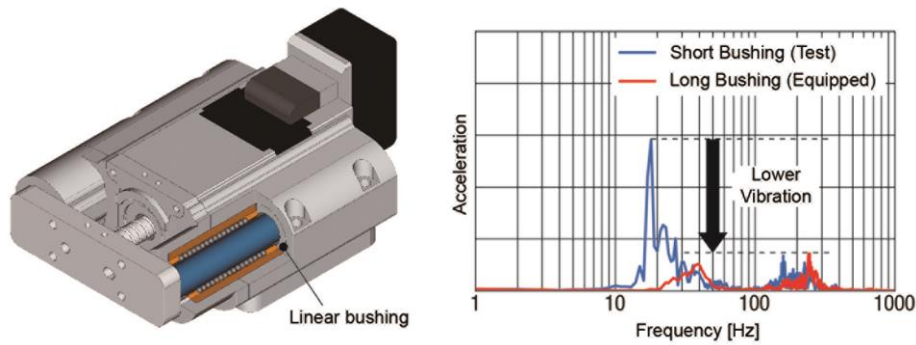

Fig. 3: Lower spindle vibrations by using longer guide bushes. Measurement in vertical direction of movement with 100 mm/s, 30 mm stroke and 2 kg load.

Another measurement was carried out with regard to the displacement of the moving parts under load (Fig. 4). Here it was found that the version with side guide achieved better results than the version with linear table. This makes the former very suitable for applications that require precise positioning despite load fluctuations.

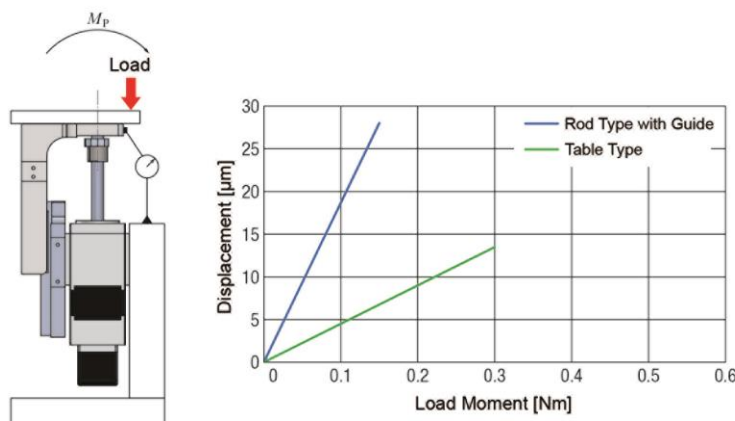

Fig. 4.: The guide version has the least offset under load, making it particularly well suited for precise positioning in the event of load fluctuations.

The linear actuators of the DR Series offer great flexibility with regard to mounting. With the help of specially designed mounting plates, almost all mounting directions can be implemented. To ensure this flexibility, the housing design has been improved compared to the previous series in that a larger housing surface rests on the mounting surface. Particularly in the version with linear table, the load is thus better distributed so that the ball bearing is protected and thus has a positive effect on the service life.

When designing the DR Series, customer requests for higher speed were also taken into account. Two different spindle pitches are available: With the 2.5 mm pitch, a maximum speed of 100 mm/s is achieved; with the 1 mm pitch, the maximum transport load is 4 kg (Fig. 5).

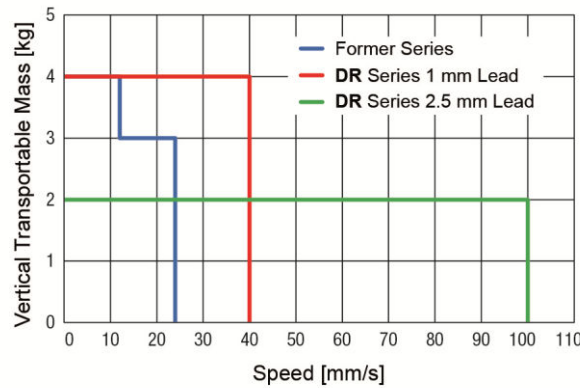

Fig. 5: The DR Series achieves speeds of up to 100 mm/s compared to the previous series.

A key feature of the linear actuators is their high positioning accuracy. Here, a laser device was used for length measurement. The repeat positioning accuracy is defined as half the error deviation from the stop position when positioning to any point in the same direction. This value is then given a plus minus sign. The real measured value was ± 0.0011 mm, specified as ± 0.003 mm at constant temperature and load. The actuators thus achieve an accuracy of one tenth of a fine hair.

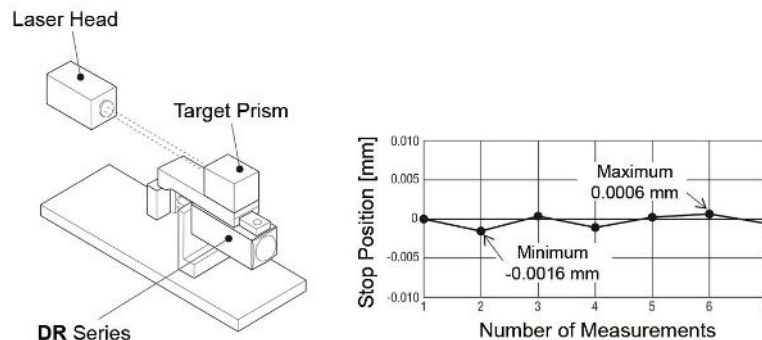

Fig. 6: The repeat positioning accuracy determined with a laser measurement is ± 0.0011 mm, specified as ± 0.003 mm at constant temperature and load.

The maximum error between theoretical and actual feed at each pulse is called feed step accuracy. This is ± 0.0004 mm for the DR Series, which means the actuators are ideal for applications with minimal feed, such as a microscope stage.

Heating and cooling operations are often performed on measuring equipment and machine tools to suppress variations due to thermal deviations of circuit elements and thermal expansion of mechanical components.

Temperature and its effect on positioning accuracy must also be considered for motors and actuators. One factor is that the temperature of the mechanical components rises due to the heat of the motor and the stop position fluctuates due to the thermal expansion of the mechanical components. However, with the DR Series, the effects are minimal: with a temperature rise of just over 30 degrees, the deviation from the stop position is less than 18 microns.

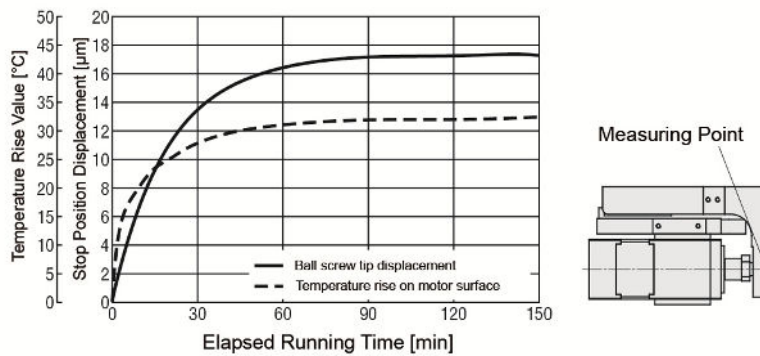

Fig. 7: The motor temperature increases with longer operating times, but this has only a minimal effect on the positioning accuracy of the DR Series with less than 18 micrometres.

As already mentioned, temperature fluctuations affect the positioning accuracy. In case of excessive thrust, heat generation can be suppressed by reducing the operating current. The AZ motor of the DR Series enables monitoring of the motor's load factor, which facilitates optimisation of the operating current. The load factor of the motor is the ratio between the actual load torque and the output torque (thrust force) during operation. The AZ motor can easily monitor the motor load factor using the MEXE02 parameterisation software.

Fig. 8 shows an example of load factor monitoring for a trapezoidal movement profile with three different operating currents. At an operating current of 40 %, the load factor reaches 100 % and there is a deviation from the set speed. In this case, possible operating faults must be expected. If, on the other hand, the operating current is set to 60 %, operation is trouble-free.

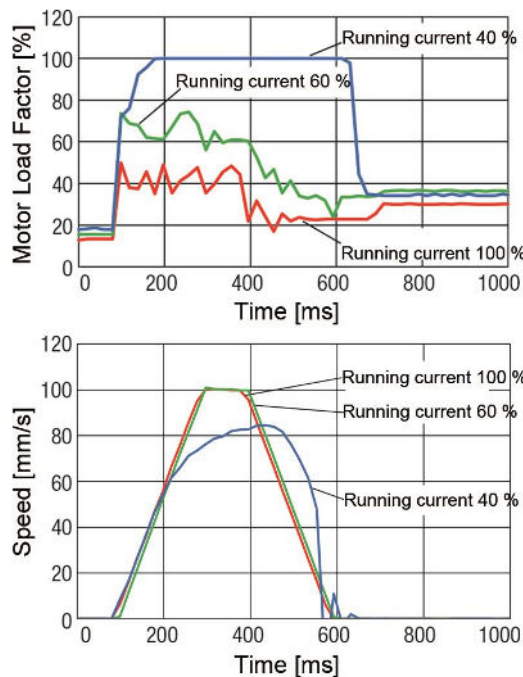

Fig. 8: With the help of load factor monitoring, the optimum operating current can be determined in order to avoid operating faults due to overload.

By reducing the operating current, it is possible to exert a positive influence on the motor temperature and thus on the stopping inaccuracy caused by heat generation. At an operating current of 100%, the temperature rise of the motor surface is 32°C, which leads to a stopping inaccuracy of 17.5 micrometres. In comparison, if the operating current is reduced to 60%, the temperature rise is only about 20°C and the deviation from the stop position drops to about 6 micrometres. This illustrates how effective load factor monitoring can be in making the most of the linear actuators' potential.

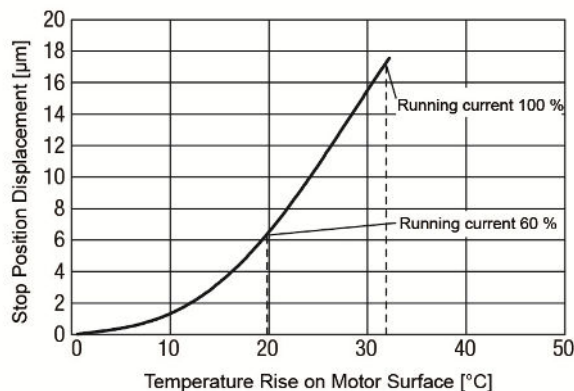

Fig. 9.: Improved stopping accuracy by reducing the operating current.

All in all, the linear actuators of the DR Series, with their compact size and high positioning accuracy, are ideal for applications where every centimetre of space saved is important, but where at the same time no compromises should be made in terms of accuracy.

Contact:

United Kingdom & Ireland: Oriental Motor (UK) Ltd., Tel: 01256-347090,
info@oriental-motor.co.uk

Other countries: Oriental Motor (Europa) GmbH, Tel: +49-211-52067-00,
info@orientalmotor.de