

# CVD Series Multi-Axis Type EtherCAT Compatible

- This compact, lightweight 4-axis control driver reduces wiring and saves valuable space.
- Can be used with 2-phase/5-phase stepper motors and electric actuators
- EtherCAT communication enables synchronous operation
- Automatically controls electromagnetic brakes using data acquired from integrated encoders
- Can reduce host controller costs and program creation time

EtherCAT



Without Mounting Plate  
Product name: **CVD4A-KED**



Right-Angle Type without Mounting Plate  
Product Name: **CVD4AR-KED**

### EtherCAT Compatible/4-Axis Control Reduces Wiring and Saves Space

- I/O signals are consolidated into a single EtherCAT communication cable. Wiring for communication, power supply, etc. for 4-axis are integrated into a single driver
- Reduces work hours for wiring and decreases problems from mis-wiring
- Integrated management of device information including motor information by using an EtherCAT master

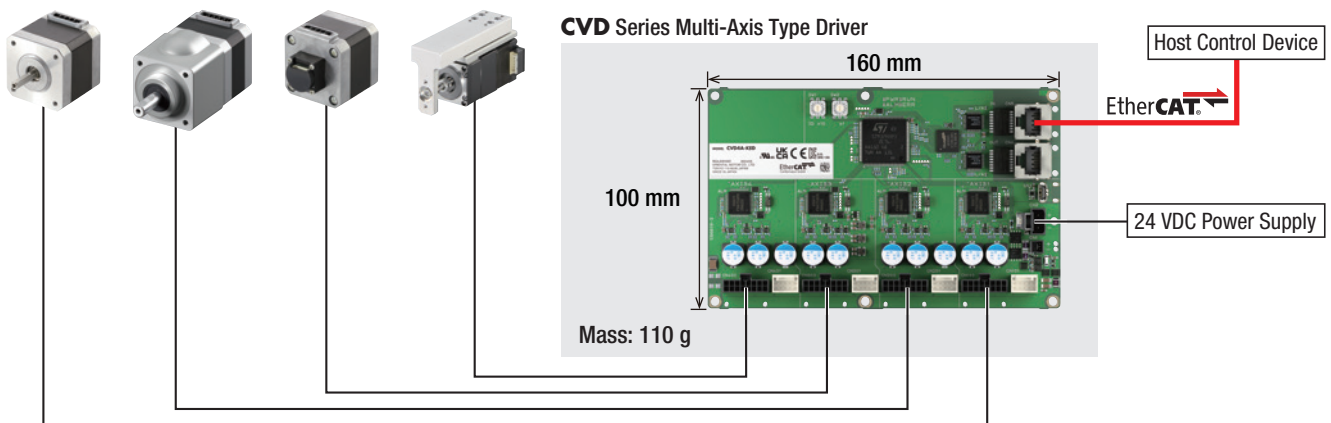

- Daisy-chain connection of multi-axis drivers is possible

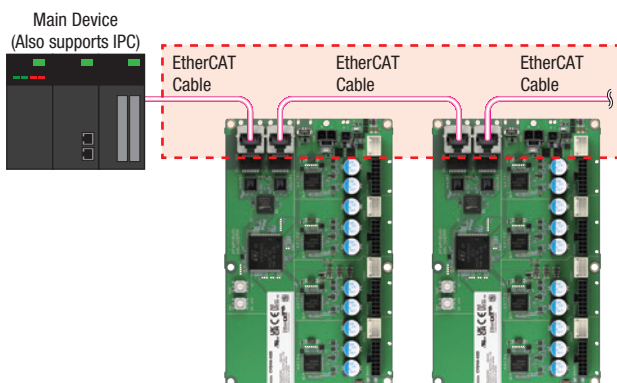

- The right-angle connector direction type can be installed with several units placed side by side, eliminating crowded wiring and saving space.

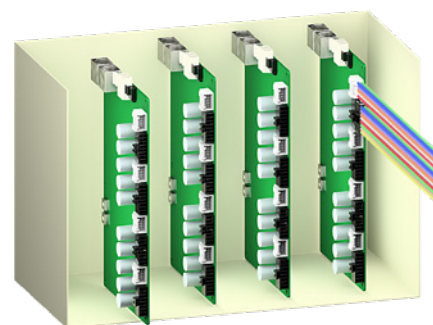

- Driver connector positions are concentrated on two sides. This simplifies wire bundling.

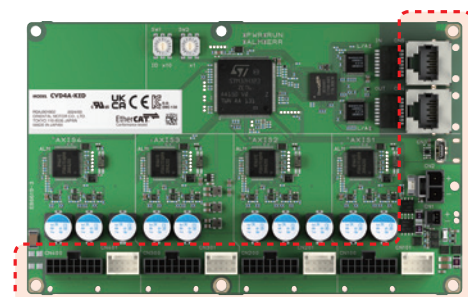

## Combined Use of 2-Phase/5-Phase Motors and Synchronous Control is Possible Using EtherCAT Communication

- A single driver can control 2-phase/5-phase motors and actuators, which reduces parts inventory and management costs
- Synchronous control is possible while utilizing the different characteristics of 2-phase/5-phase motors via EtherCAT communication

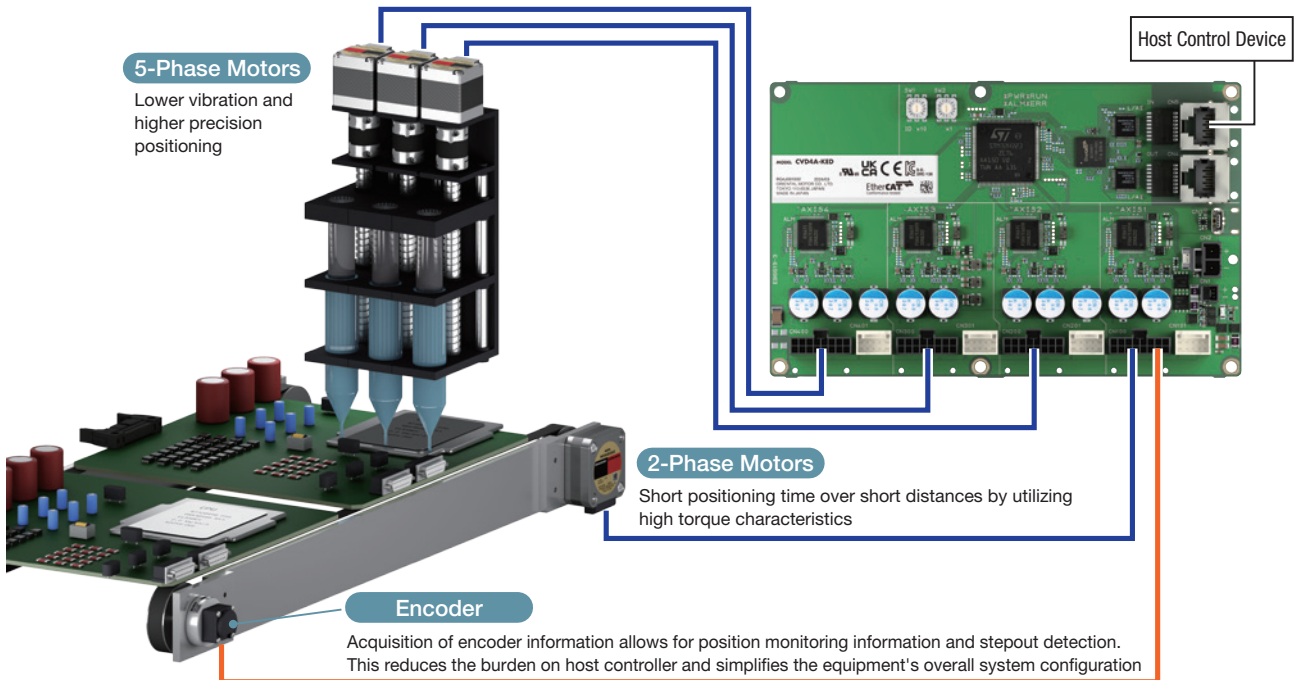

## Many Combinations of Motors, Actuators, and Rotary Encoders are Possible

### 2-Phase Stepper Motor **PKP** Series Bipolar 4 Lead Wires

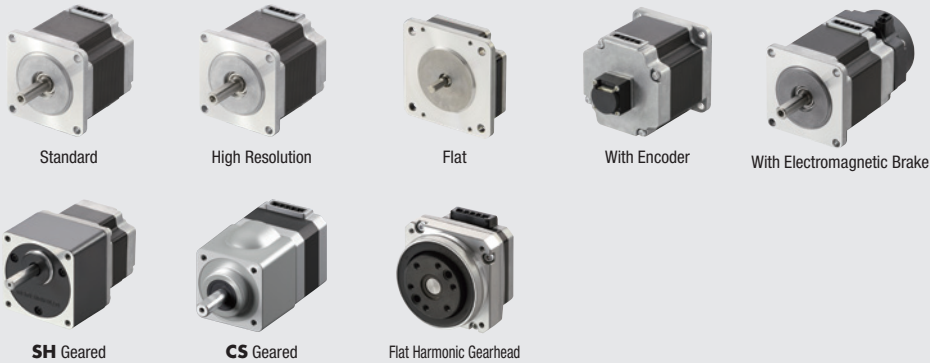

### Rotary Encoder

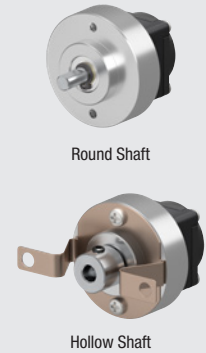

### 5-Phase Stepper Motors **PKP/PK** Series

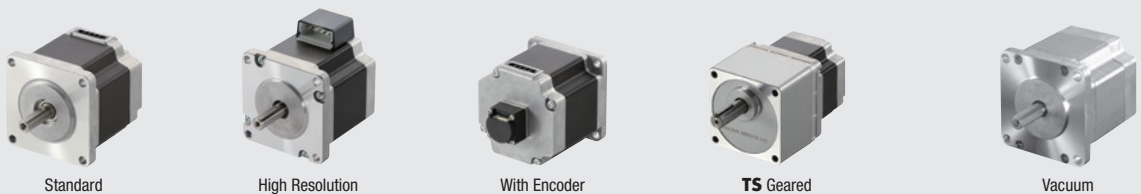

(Must check combination conditions, etc. Please contact Oriental Motor for details.)

### Compact Electric Cylinder **DRL II** Series



### Hollow Rotary Actuator **DH** Series



### Mounting Adapter for Linear Actuator & Stepper Motor **PKP** Series

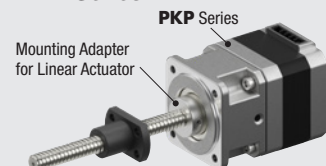

## List of Combinations with the CVD Multi Axis Drivers

- 4 motors with input current of 0.5 to 3.0 A\* (per axis) can be connected. (Max. 12 A per 1 driver)
  - Can be combined with vacuum motors , but must check combination conditions, etc. Please contact Oriental Motor for details.
- \*Varies depending on the combined product.

Product Line	Series	Combined Products*1	Rated Current [A/Phase]
2-Phase Stepper Motors	PKP Series Bipolar 4 Lead Wires	PKP203D06A	0.6
		PKP213D05	0.5
		PKP214D06	0.6
		PKP22D15, PKP22D152, PKP22MD15	1.5
		PKP23D15	1.5
		PKP23D23	2.3
		PKP24D082	0.8
		PKP24D15, PKP24D152, PKP24MD15, PKP24MD152	1.5
		PKP24D23, PKP24D232	2.3
		PKP25D28A2	2.8
		PKP26D142	1.4
		PKP26FD15A	1.5
		PKP26D28, PKP26D282, PKP26MD28, PKP26MD282	2.8
5-Phase Stepper Motors	PKP Series	PKP52MN03, PKP52N03	0.3
		PKP52MN07, PKP52N07	0.7
		PKP52N12	1.2
		PKP54MN, PKP54N18, PKP54N182	1.8
		PKP56FMN, PKP56FN242	2.4
	PK Series	PK513, PK52P	0.35
		PK52H, PK54	0.75
		PK56*2	1.4
Hollow Rotary Actuator	DH Series	DHM28PAK2, DHM42PAK	0.75
Compact Electric Cylinders	DRL II Series	DRLM20	0.35
		DRLM28, DRLM42	0.75
		DRLM60	1.4

\*1 Some product names are listed here. Can be combined with products containing the product names listed here.

Note that motors with voltage output type encoders are not listed.

A number indicating the length of the motor case is entered where the box □ is located within the motor product name.

Either **A** (single shaft), **B** (double shaft) or **M** (type with an electromagnetic brake) indicating the configuration is specified where the box ■ is located in the product name.

\*2 This applies to motors with a rated current of 1.4 A/phase.

# Acquire Encoder Information and Position Deviation Detection

Driver includes a function to acquire encoder information. Position deviation can be detected by the driver and outputs a signal without the need for a host controller. The actual position and speed of the motor can also be monitored on a computer screen by using the support software **MEXE02**.

- No high-speed counter needed, reducing host controller costs
- Outputs signal to the host controller using EtherCAT communication. Reduces program creation time.

## ● CVD Series Multi-Axis Type

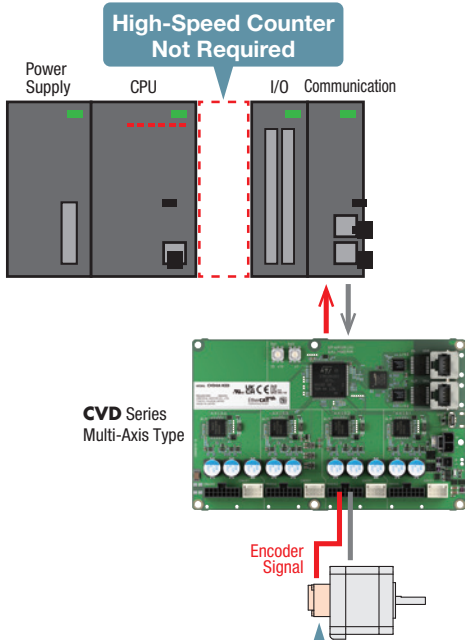

## ● Conventional Product

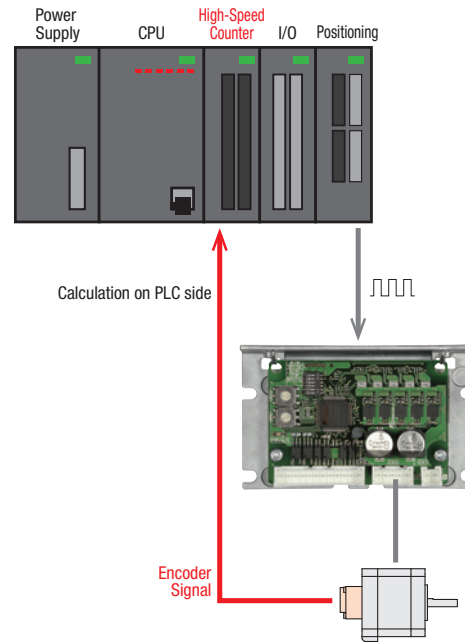

### Compatible with both motors with encoders and rotary encoders

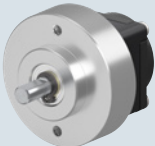
PKP Series With Encoder	Rotary Encoder
	
<p>Resolution</p> <p>2-Phase Motors: 200 P/R, 400 P/R, 1000 P/R</p> <p>5-Phase Motors: 500 P/R, 1000 P/R</p>	<p>Resolution</p> <p>1000 P/R, 2000 P/R</p>

Encoder Input Unit Specifications		
Classification	Description	Description
A-Phase B-Phase	Output Type	Incremental
	Maximum Frequency	500 kHz (frequency for each of A-phase and B-phase)
	Edge Interval	500 nsec min.
	Count Range	-2,147,483,648 ~ +2,147,483,647 count
	Count Method	90-degree phase difference input
Z-Phase	Multiplier	Quadrupling
	Interface	Differential receiver*
5 VDC Power Supply	Input Width	1 ms min.
	Interface	Differential receiver*
Output	Output Voltage	5 VDC ± 10%
	Output Current	200 mA max.

\*The electrical characteristics of the encoder to be connected should be equivalent to 26C31.

## ● The Encoder Detection Information can be Monitored Using the Support Software **MEXE02** (Free)

Measurement results can be saved as image files or data in CSV format

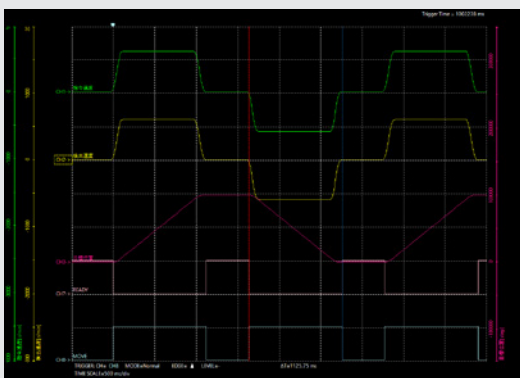

## Automatic Control of Electromagnetic Brake and Power Supply

- No electromagnetic brake control circuit is needed, which reduces program creation time
- Reduced wiring work time

### ● CVD Series Multi-Axis Type

Control Power Supply/  
Control Circuit for  
Electromagnetic Brake  
Not Required

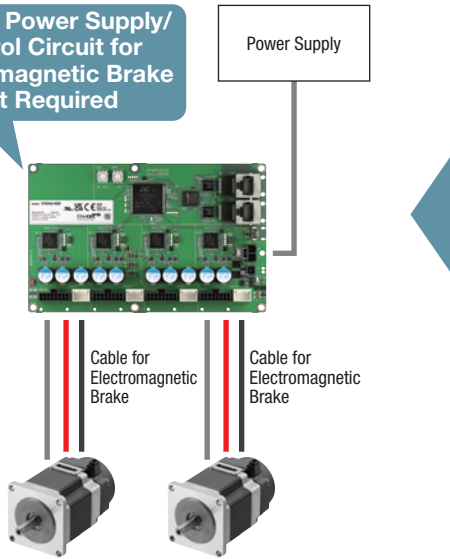

### ● Conventional Product

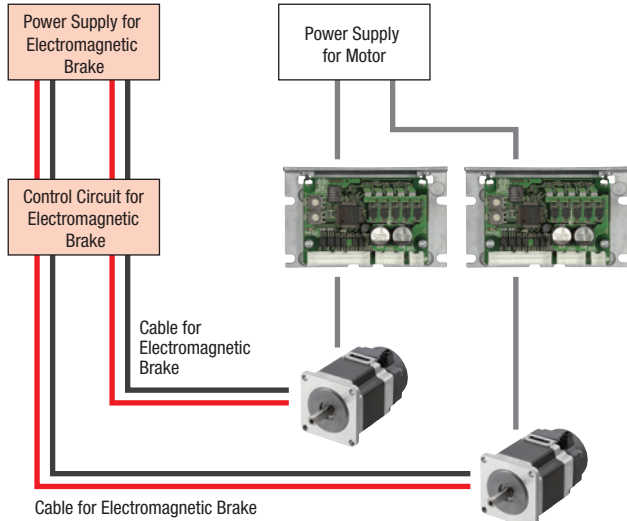

## Can Provide Power to Sensors

### ● CVD Series Multi-Axis Type

External Power  
Supply for Sensor  
Not Required

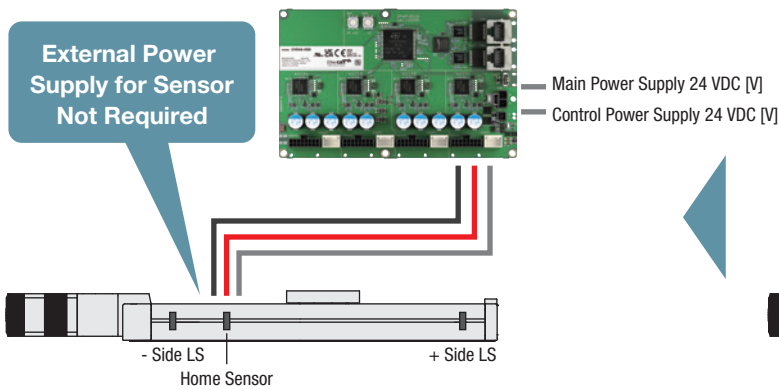

### ● Conventional Product

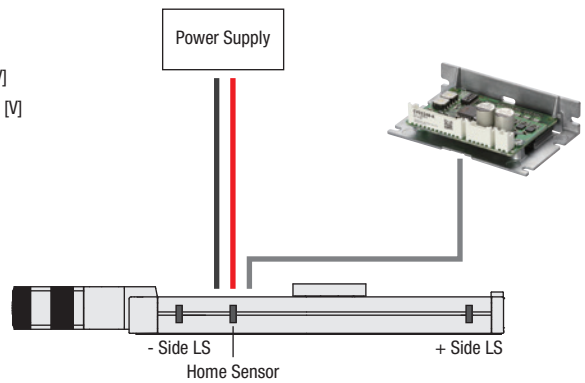

## Other Functions

### ● Alarm Output

- Output of an excessive position deviation alarm allows for detection of motor misstep/stepout (Main circuit overheat alarm, etc. can also be output)

### ● Information

- Can output driver temperature, overvoltage, undervoltage, etc. as general information
- Can be monitored using EtherCAT communication

### ● Separation of Main Power and Control Power

- Supports addition of a separate external safety relay to shut off the main power supply
- Monitoring, etc. via EtherCAT communication is possible even when the main power supply is shut off

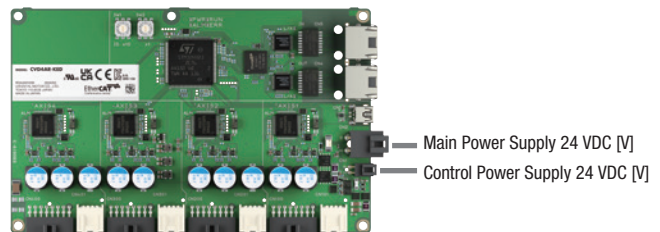

### ● Main Power Supply Inrush Current Suppression Function

- This function protects the circuits in the main power supply unit from inrush currents that occur when the main power supply is turned on.

# Support from Startup to Maintenance with the Support Software MEXE02

In addition to setting and editing the operating data and various parameters, teaching and monitoring various operating conditions can be performed using the support software **MEXE02**.

## Startup and Evaluation

Various functions that are useful during wiring checks and test operation are available.

- Parameter setting
- Status monitor for all axes
- PDO monitor
- Remote operation

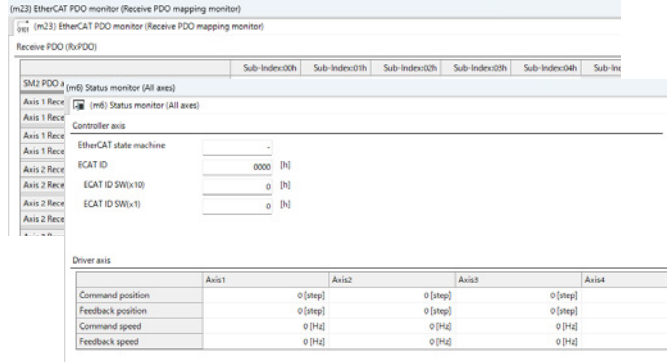

## Adjustment

Functions to help adjust motor operation after the equipment is installed are available.

- Waveform monitor
- Velocity demand value of motors, etc. can be monitored like an oscilloscope
- Waveform measurement results can be saved as images and in CSV format

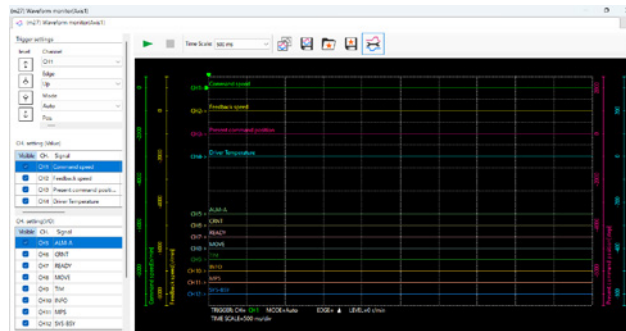

## Diagnostics and Maintenance

Useful functions for diagnosis and maintenance in case of trouble after the start of operation are available.

- Alarm monitor
- Unit information monitor
- Status monitor

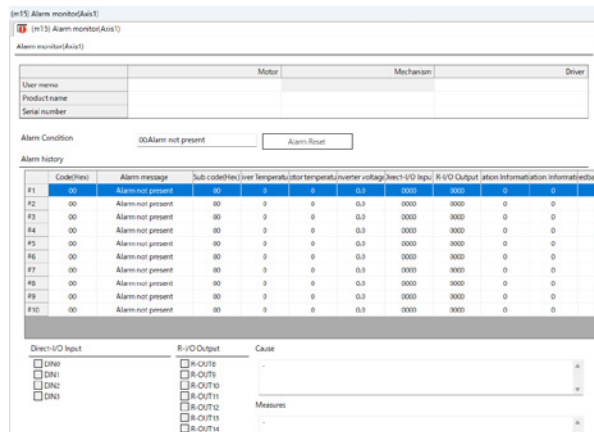

# Names and Functions of Driver Parts

Parameters can be set using the support software **MEXE02** or EtherCAT communication.

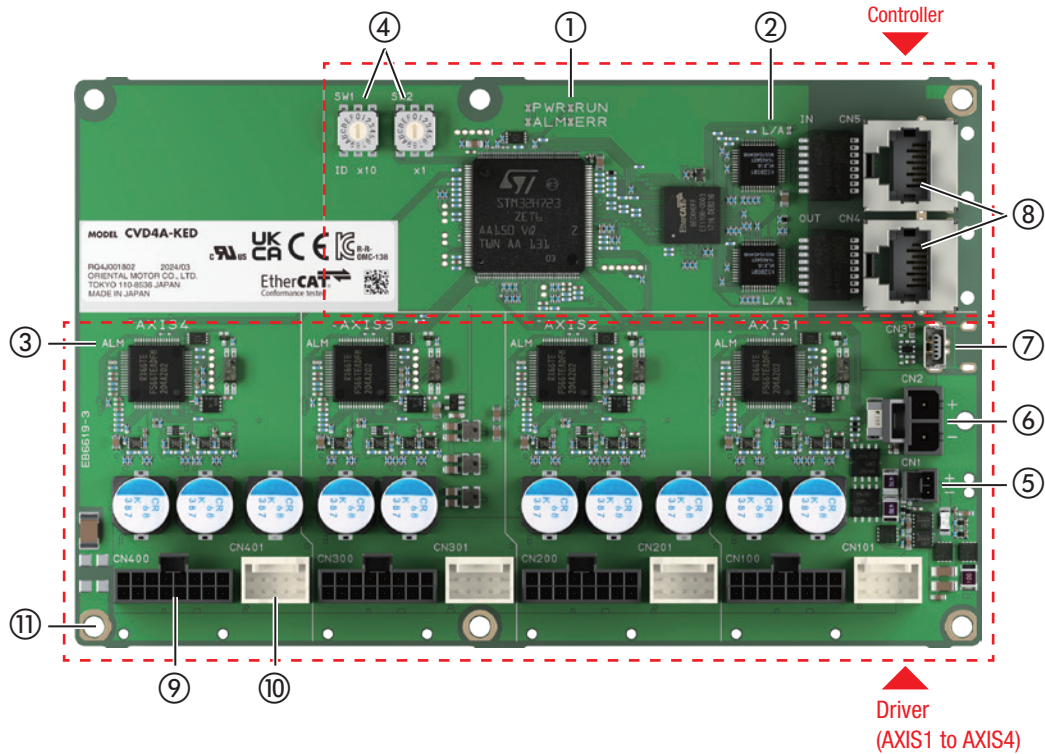

No.	Name	Description
①	PWR LED (Green)	Illuminated green when the main power supply is ON.
	RUN LED (Green)	Displays the EtherCAT communication status.
	ALM LED (Red)	Flashes or illuminates when an alarm is activated in the controller unit.
	ERR LED (Red)	Flashes when an error has occurred in the EtherCAT communication.
②	L/A LED (Green)	Displays the EtherCAT LINK/ACT status.
③	ALM1 ~ ALM4 LED (Red)	Flashes when an alarm is activated in the driver unit.
④	Node Address Setting Switch [SW1 (×10), SW2 (×1)]	Sets the driver's node address. Factory default settings: 0 [SW1 (×10): 0, SW2 (×1): 0]
⑤	Control Power Connector [CN1]	Connects the control power supply. (24 VDC)
⑥	Main Power Connector [CN2]	The main power supply is connected. (24 VDC)
⑦	USB Communication Connector [CN3]	Connects to the computer on which the data setting software <b>MEXE02</b> is installed using a USB cable. (USB 2.0 mini-B port)
⑧	EtherCAT Connectors [CN5 IN, CN4 OUT]	<ul style="list-style-type: none"> <li>• CN5 IN: Connects to host-side EtherCAT compatible products.</li> <li>• CN4 OUT: Connects to the EtherCAT compatible device with the next machine number.</li> </ul>
⑨	Motor Connectors [CN100, CN200, CN300, CN400]	Connects to the motor, electromagnetic brake and encoder.
⑩	I/O Connectors [CN101, CN201, CN301, CN401]	Connects the I/O signals.
⑪	Mounting Hole	Mount the driver using a screwdriver.

## Product Specifications

Main Power Supply	Input Voltage	24 VDC ± 10%
Main Power Supply	Max. Input Current	0.5 ~ 3.0 A per axis* (Max. 12 A)
Control Power Supply	Input Voltage	24 VDC ± 5%
Control Power Supply	Max. Input Current	1.3 A (Excludes sensor power supply)
Control Input		4 Points, Photocoupler
Control Output		1 Point, Photocoupler and Open-Collector
Field Network		EtherCAT

\*Varies depending on the combined product.

## Communication Specifications

Communication Protocol	IEC 61158 Type12
Physical Layer/Protocol	100 BASE-TX (IEEE 802.3)
Transmission Rate	100 Mbps
Communication Cycle	<ul style="list-style-type: none"> <li>Free Run Mode: 1 ms min.</li> <li>Sync Manager 2 Event Synchronization Mode: 1 ms min.</li> <li>DC Mode: 0.5 ms, 1 ms, 2 ms, 3 ms, 4 ms, 5 ms, 6 ms, 7 ms, 8 ms</li> </ul>
Communication Port/Connector	RJ45 × 2 (Shield-compatible) ECAT IN: EtherCAT input ECAT OUT: EtherCAT output
Topology	Daisy Chain (Max. 65,535 nodes)
Process Data	Variable PDO Mapping
Sync Manager	<ul style="list-style-type: none"> <li>SM0: Mailbox output</li> <li>SM1: Mailbox input</li> <li>SM2: Process data output</li> <li>SM3: Process data input</li> </ul>
Mailbox (CoE)	<ul style="list-style-type: none"> <li>Emergency Messages</li> <li>SDO Request</li> <li>SDO Response</li> <li>SDO Information</li> </ul>
Synchronization Mode	<ul style="list-style-type: none"> <li>Free Run Mode (Asynchronous)</li> <li>Sync Manager 2 Event Synchronization Mode</li> <li>DC Mode (SYNC0 event synchronization)</li> </ul>
Device Profile	IEC 61800-7 CiA402 Drive Profile

## Dimensions (Unit = mm)

### Without Mounting Plate

Mass 0.11 kg

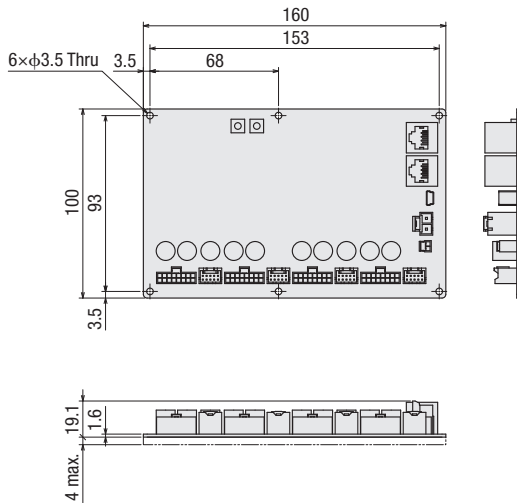

### Right-Angle Type without Mounting Plate

Mass 0.11 kg

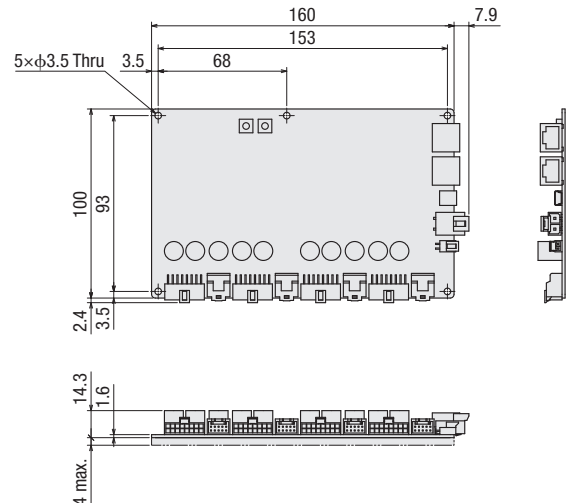

## Motor Connection Cable - Driver side

Product Code	Type	Length [m]
<b>LCD06CA-2M</b>	2 Phase Standard Type	0.6
<b>LCD06CA-2MB</b>	2 Phase with Electromagnetic Brake	
<b>LCD06CA-2ME</b>	2 Phase with Encoder	
<b>LCD06CA-5M</b>	5 Phase Standard Type	
<b>LCD06CA-5MB</b>	5 Phase with Electromagnetic Brake	
<b>LCD06CA-5ME</b>	5 Phase with Encoder	

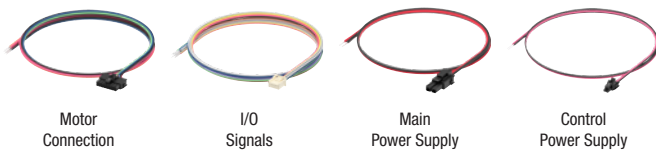

## Cable for I/O Signals

Product Code	Type	Length [m]
<b>LCD06CA-S</b>	Cable for I/O Signals	0.6

## Cable for Main Power Supply

Product Code	Type	Length [m]
<b>LC02D06C</b>	Cable for Main Power Supply	0.6

## Cable for Control Power Supply

Product Code	Type	Length [m]
<b>LC02D06C</b>	Cable for Control Power Supply	0.6

**Orientalmotor**

Specifications are subject to change without notice. This catalogue was published in January 2025.

www.orientalmotor.eu



Customer Service Center (German & English)  
Free Hotline 00800-22 55 66 22 - info@orientalmotor.de

These products are manufactured at plants certified with the international standards ISO 9001 (for quality assurance) and ISO 14001 (for systems of environmental management).